



# PFC Choke

For STMicroelectronics  
L6562 PFC Controller

This power factor correction choke is designed specifically for the STMicroelectronics L6562 PFC controller. It is intended for use in IEC61000-3-2 compliant switch mode power supplies used in televisions, desktop PCs and high-end ac-dc adapters/chargers.

The EB0057-DL is the RoHS-compliant version of the EB0057-C. It is electrically identical and fits the recommended PC board layout.

Coilcraft can design custom transformers with voltage, inductance and DCR values to meet your specific requirements. Contact Coilcraft for more information or for free evaluation samples.

**Core material** Ferrite

**Terminations** RoHS compliant tin-silver over tin over copper-clad steel. Other terminations available at additional cost.

**Weight** 75 g

**Ambient temperature** -40°C to +85°C

**Storage temperature** Component: -40°C to +85°C.  
Tray packaging: -40°C to +80°C

**Moisture Sensitivity Level (MSL)** 1 (unlimited floor life at <30°C / 85% relative humidity)

**Packaging** 50 parts per tray

**PCB washing** Tested with pure water or alcohol only. For other solvents, see Doc787\_PCB\_Washing.pdf.

Part number	Inductance <sup>1</sup> ±10% (µH)	Primary DCR max (Ohms)	Isolation <sup>2</sup> (Vrms)	Turns ratio pri : aux	Isat <sup>3</sup> (A)	Irms <sup>4</sup> (A)
EB0057-DL	150	0.09	4800	8 : 1	10.0	4.0

1. Inductance measured at 50 kHz, 0.1 Vrms, 0 Adc.
2. Isolation measured from pins 1 and 2 to pins 13 and 14 with voltage applied for 2 seconds.
3. DC current at which the inductance drops 10% (typ) from its value without current.
4. Current that causes a 40°C temperature rise from 25°C ambient.
5. Electrical specifications at 25°C.

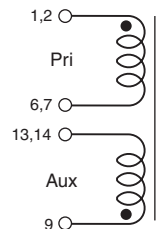
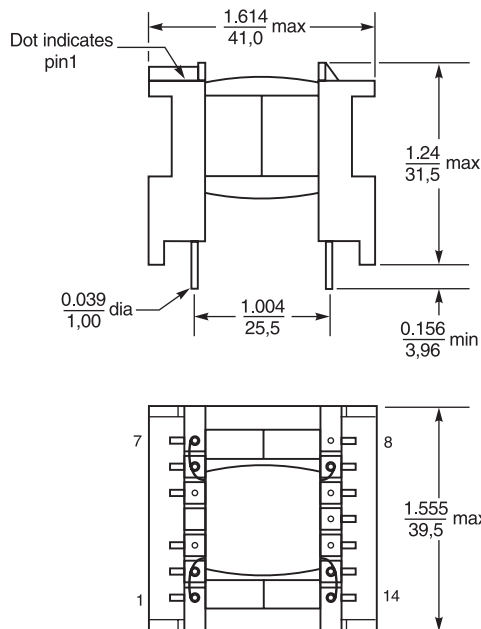

The windings are connected internally as shown

### Recommended Board Layout

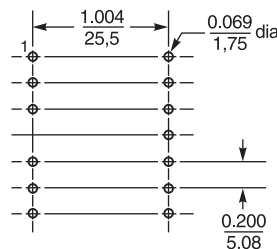

Dimensions are in  $\frac{\text{inches}}{\text{mm}}$



www.coilcraft.com

**US** +1-847-639-6400 sales@coilcraft.com  
**UK** +44-1236-730595 sales@coilcraft-europe.com  
**Taiwan** +886-2-2264 3646 sales@coilcraft.com.tw  
**China** +86-21-6218 8074 sales@coilcraft.com.cn  
**Singapore** + 65-6484 8412 sales@coilcraft.com.sg

Document 395 Revised 12/29/21

© Coilcraft Inc. 2021

This product may not be used in medical or high risk applications without prior Coilcraft approval. Specification subject to change without notice. Please check web site for latest information.