

**NEW!**

# Wirewound Ferrite Beads 0805PB (2012)



- Optimized for high-frequency noise suppression on high-current power supply lines
- Current ratings as high as 4.4 Amps
- AEC-Q200 Grade 1 (-40°C to +125°C)
- Wider spectrum of suppression than traditional ferrite beads
- Robust mechanical structure for use in automotive applications and other harsh environments

Part number <sup>1</sup>	Impedance <sup>2</sup> 100 MHz ±20% (Ohms)	Impedance 900 MHz (Ohms)	Impedance 1.7 GHz (Ohms)	Inductance typ <sup>3</sup> (µH)	SRF typ <sup>4</sup> (MHz)	DCR max <sup>5</sup> (mOhms)	I <sub>rms</sub> (A)		
							25°C <sup>6</sup>	85°C <sup>7</sup>	125°C <sup>8</sup>
0805PB-250XMR_	25	75	120	0.10	3200	12.2	4.40	3.96	2.25
0805PB-101XMR_	100	250	400	0.40	1800	19.0	3.20	2.88	1.64
0805PB-221XMR_	220	700	1000	0.90	1100	30.5	3.00	2.70	1.53
0805PB-331XMR_	330	1100	1350	1.2	950	37.8	2.40	2.17	1.23
0805PB-601XMR_	600	1700	1700	2.3	680	62.2	1.90	1.70	0.96
0805PB-102XMR_	1000	2700	1500	3.6	480	139.1	1.40	1.26	0.71

1. When ordering, please specify **termination** and **packaging** codes:

**0805PB-102XMR\_C**

**Termination:** **R** = RoHS compliant matte tin over nickel over silver  
Special order: **Q** = RoHS tin-silver-copper (95.5/4/0.5) or **P** = non-RoHS tin-lead (63/37).

**Packaging:** **C** = 7" machine-ready reel. EIA-481 embossed plastic tape (2000 parts per full reel). Quantities less than full reel available: in tape (not machine ready) or with leader and trailer (\$25 charge).

**D** = 13" machine-ready reel. EIA-481 embossed plastic tape. Factory order only, not stocked (7500 parts per full reel).

2. Impedance measured at 100 MHz at 0.5 V<sub>rms</sub>, using E4982 (or equivalent) with correlation.
  3. Inductance measured at 100 KHz at 0.1 V<sub>rms</sub>, using Coilcraft SMD-A fixture on an Agilent 4263 (or equivalent) without correlation.
  4. SRF is measured on an Agilent 8753ES (or equivalent) with a Coilcraft SMD-D test fixture.
  5. DCR is measured on a Keithley 580 Micro-ohmmeter (or equivalent) with a Coilcraft CCF858 test fixture.
  6. Current that cause 40°C rise at 25°C.
  7. Current that cause 40°C rise at 85°C.
  8. Current that cause 15°C rise at 125°C.
  9. Electrical specifications at 25°C.
- Refer to Doc 362 "Soldering Surface Mount Components" before soldering.

**Core material** Ferrite

**Environmental** RoHS compliant without exemption, halogen free

**Terminations** RoHS compliant matte tin over nickel over silver. Other terminations available at additional cost.

**Weight** 14.0 – 15.5 mg

**Ambient temperature** -40°C to +125°C with I<sub>rms</sub> current

**Maximum part temperature** +140°C (ambient + temp rise). [Derating](#).

**Storage temperature** Component: -40°C to +140°C.

Tape and reel packaging: -40°C to +80°C

**Resistance to soldering heat** Max three 40 second reflows at +260°C, parts cooled to room temperature between cycles

**Moisture Sensitivity Level (MSL)** 1 (unlimited floor life at <30°C / 85% relative humidity)

**Packaging** 2000/7" reel; 7500/13" reel; Plastic tape: 8 mm wide, 0.23 mm thick, 4 mm pocket spacing, 1.3 mm pocket depth

**PCB washing** Tested to MIL-STD-202 Method 215 plus an additional aqueous wash. See [Doc787\\_PCB\\_Washing.pdf](#).

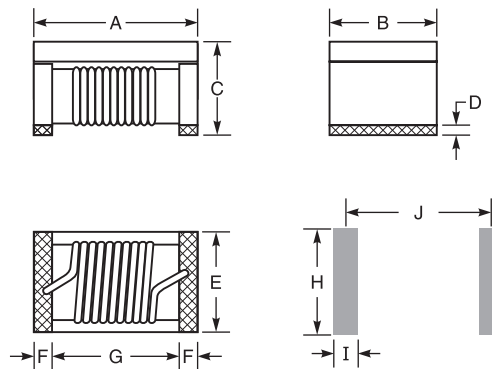

**Recommended Land Pattern**

A	B	C	D	E	F	G	H	I	J
max	max	max	ref	ref	ref	ref	nom	nom	nom
0.086	0.054	0.047	0.006	0.050	0.018	0.096	0.055	0.026	0.066
2,18	1,37	1,20	0,15	1,27	0,46	2,44	1,40	0,66	1,68



# Wirewound Ferrite Beads – 0805PB Series

## Impedance vs Frequency

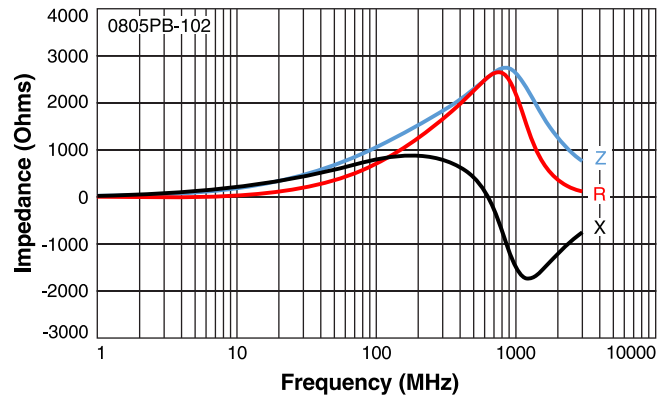
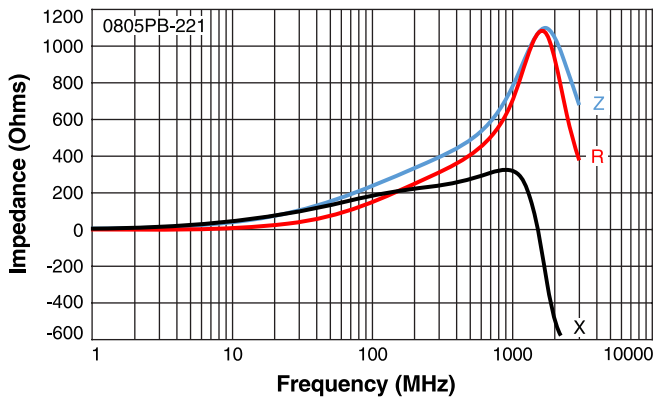
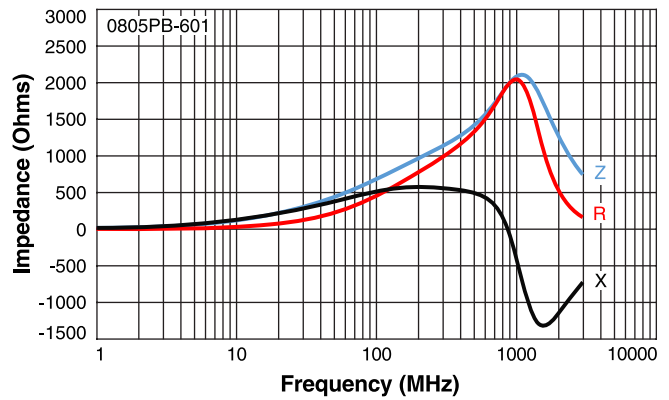
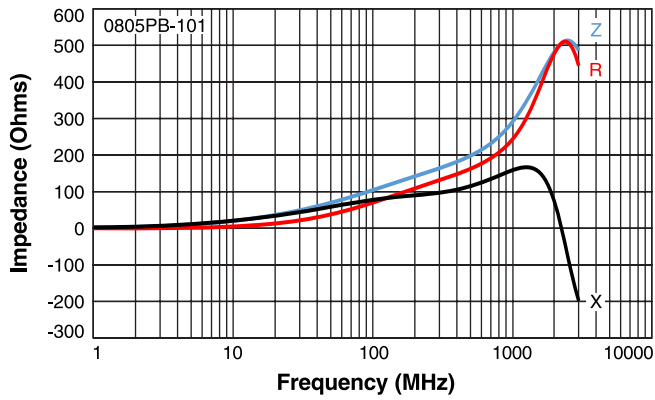
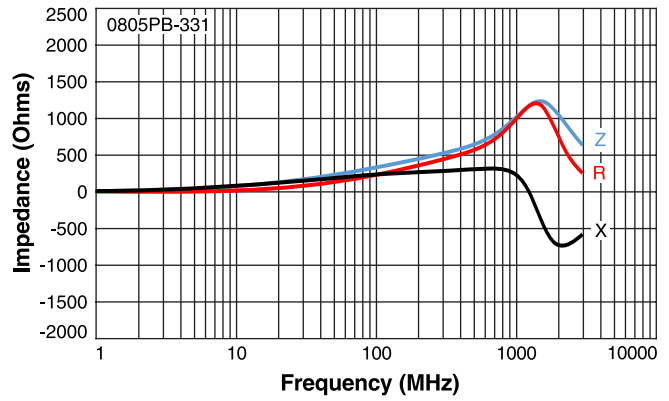
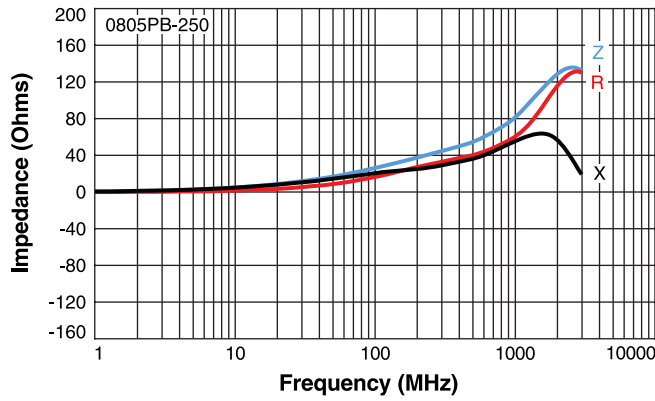

**US** +1-847-639-6400 sales@coilcraft.com  
**UK** +44-1236-730595 sales@coilcraft-europe.com  
**Taiwan** +886-2-2264 3646 sales@coilcraft.com.tw  
**China** +86-21-6218 8074 sales@coilcraft.com.cn  
**Singapore** + 65-6484 8412 sales@coilcraft.com.sg

Document 1692-2 Revised 06/07/23

© Coilcraft Inc. 2023

This product may not be used in medical or high risk applications without prior Coilcraft approval. Specification subject to change without notice. Please check web site for latest information.